

NOTES:

1. MATERIAL: 3/16" THK., POLYESTER NEEDLE FELT, GRADE F-1 OR F-3, "McMASTER-CARR" NO. 8877K43 OR 8877K52
2. DRILL, PUNCH OR CUT INNER HOLE, SIZED AS NECESSARY TO FIT SNUGGLY OVER A $\phi 0.250$ DRILL BIT. BIT SHOULD BE TIGHT IN THE FELT HOLE, BUT ABLE TO BE ROTATED BY HAND.
3. DELIVER FINISHED PARTS IN BAG MARKED "WIPER SEAL, ERS-018".

REVISIONS				
NO	DESCRIPTION	DATE	BY	APR/DATE
0	ISSUED FOR MANUFACTURE	05/12/10		

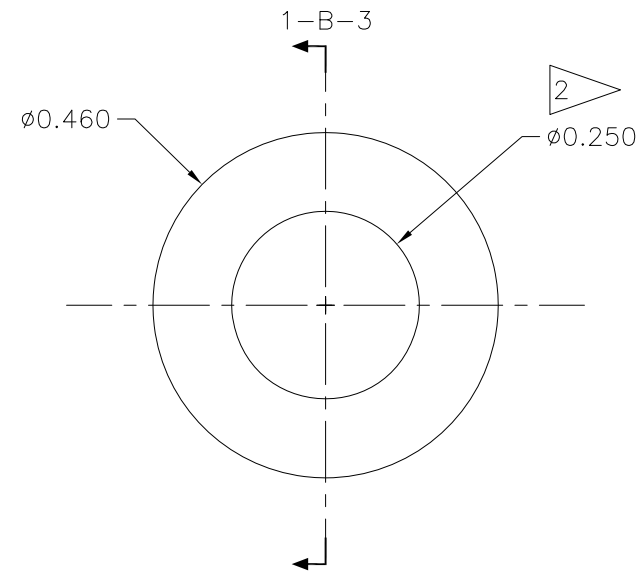

END VIEW 1-B-5
FELT WIPER SEAL

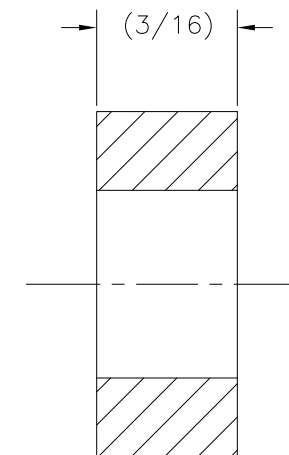

SECTION 1-B-3
REF. 1-C-5

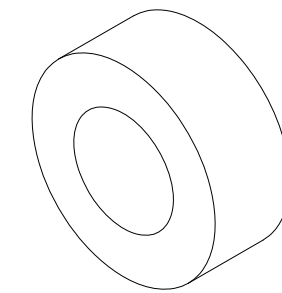

SECTION 1-B-3
REF. 1-C-5

TOLERANCES: UNLESS OTHERWISE SPECIFIED 0.X ± 0.030 0.XX ± 0.010 0.XXX ± 0.005 ANGLES ± 1/2° BREAK EDGES 0.015 x 45° MIN. FINISH 125 ✓ [0.010]A ALL DIMS ARE IN INCHES, UNLESS NOTED OTHERWISE.	PROPRIETARY NOTICE THIS DRAWING AND THE INFORMATION IT CONTAINS ARE CONSIDERED CONFIDENTIAL, AND MAY NOT BE REPRODUCED, COPIED OR USED, IN PART OR IN WHOLE, WITHOUT PRIOR WRITTEN CONSENT.	Integrated Ocean Drilling Program TEXAS A&M UNIVERSITY 1000 DISCOVERY DRIVE COLLEGE STATION, TX 77845			
		SHEET 1 OF 1 SCALE 1:8		TITLE FELT WIPER SEAL SYSTEM ASSEMBLY 3" ERS	
BY KM DATE 04/30/10	APPROVED TP	CHECKED JCS	SIZE D P/N ERS-018	REV. 0	